

Shinhoo

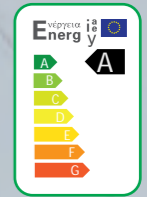

ErP
Ready

HIGH EFFICIENCY

High Efficiency Circulation Pump



Shinhoo

Anhui Shinhoo Canned Motor Pump Co., Ltd.

No.780, Ming Chuan Road, High-Tech Zone ,Hefei, Anhui, P.R China

Tel: +86 551 62379803/07 Fax: +86 551 62379801 Web: www.shinhoodump.com

HIGH EFFICIENCY

High Efficiency Circulation Pump

As a member units of national pump standardization technical committee as well as Crane, Metallurgical Motors and Canned Motors standardization technical committee of national electric rotating machinery standardization technicalcommittee, we participated drafting work of a series of standards regarding canned motor and canned motor pumps. We are committed to product research and development as well as quality promotion with orientation of customers' requirement. We offer professional solutions for general and special requirements regarding non-leakages delivery of various kinds for fluid. Our products are sold abroad to many countries in America, Europe, Asia and other areas, being widely used in chemical industry, petrification, petroleum refining, textile industry, locomotive, central air conditioning, aerospace, military industry, nuclear power, air conditioning system cooling and heating circulation, construction, environment protection, ventilation and new energy. With reliable quality and attentive-service, we have gained a high reputation in the market.

We sincerely hope to cooperate with you for a splendid future together.

TABLE OF CONTENTS

05

Brief Introduction

06

Product Introduction

34

Mega

42

Instant S

08

Classic S

16

Classic E

46

Instant

50

Grand HQ

22

Master D

28

LPA



BRIEF INTRODUCTION

(Shinhoo) As a wholly-owned subsidiary of Zhejiang Dayuan Pumps Industrial Co., Ltd. (Shanghai Stock Exchange-stock code: 603757), Shinhoo is specialized in canned motor pump manufacturing. In order to satisfy the rising market demands, in 2007 our large production base was constructed with the total investment of 300 million Chinese Yuan in National Hi-tech Development Zone in Hefei, Anhui Province, P.R. China. At the end of 2009, our new plant with the floor area of 100,000 square meters started running. Based on the standard of ISO 9001:2015 Quality Management System, ISO14001:2015 Environment Management System and OHSAS18001:2007 Occupation Health and Safety Management System, Shinhoo established a complete set of design, producing, marketing and service system. As required by different countries and areas, our related products successfully obtained certifications such as CCC, GS, UL and CE as well as passed required tests such as RoHS, REACH and EEI. All of these ensured the safety, stability, reliability, durability and legality of our products in the market. We have formed our own core competitiveness as well as the space for sustainable development with sufficient material resources, reinforced regulation system and hightech talents we gathered.

PRODUCT INTRODUCTION

FEATURES:

Shinhoo high efficiency circulation pump which features well-designed compact structure, integrated controller and frequency converter. It is easy for installation and operation in most fields of applications. In terms of electricity consumption, the unique operation mode makes Shinhoo high efficiency circulation pump more energy saving.

FIELDS OF APPLICATIONS:

1. System with constant or variable flow
2. System with variable temperature liquid
3. System with night mode
4. Air conditioning and cooling system
5. Industrial circulation system
6. Domestic hot water and drinking water supply system

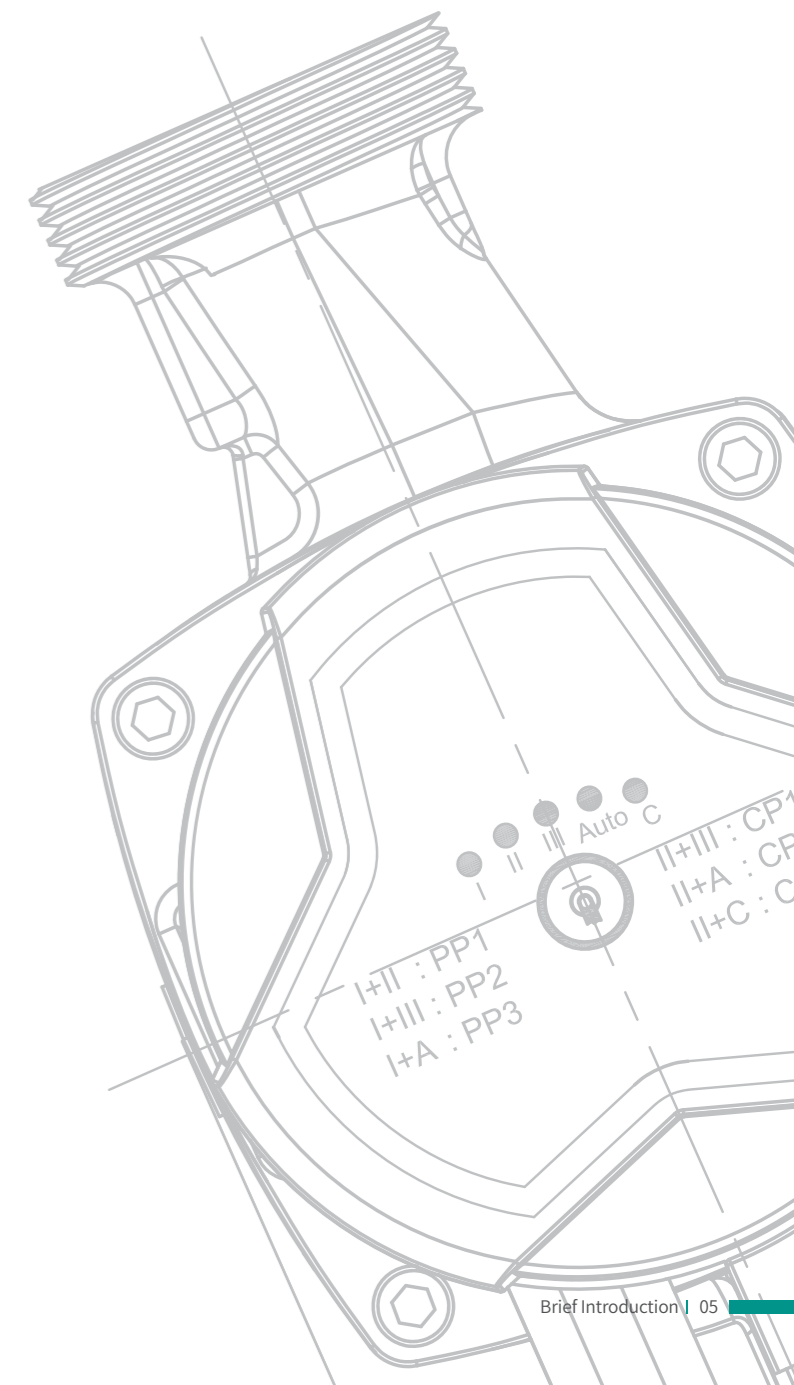
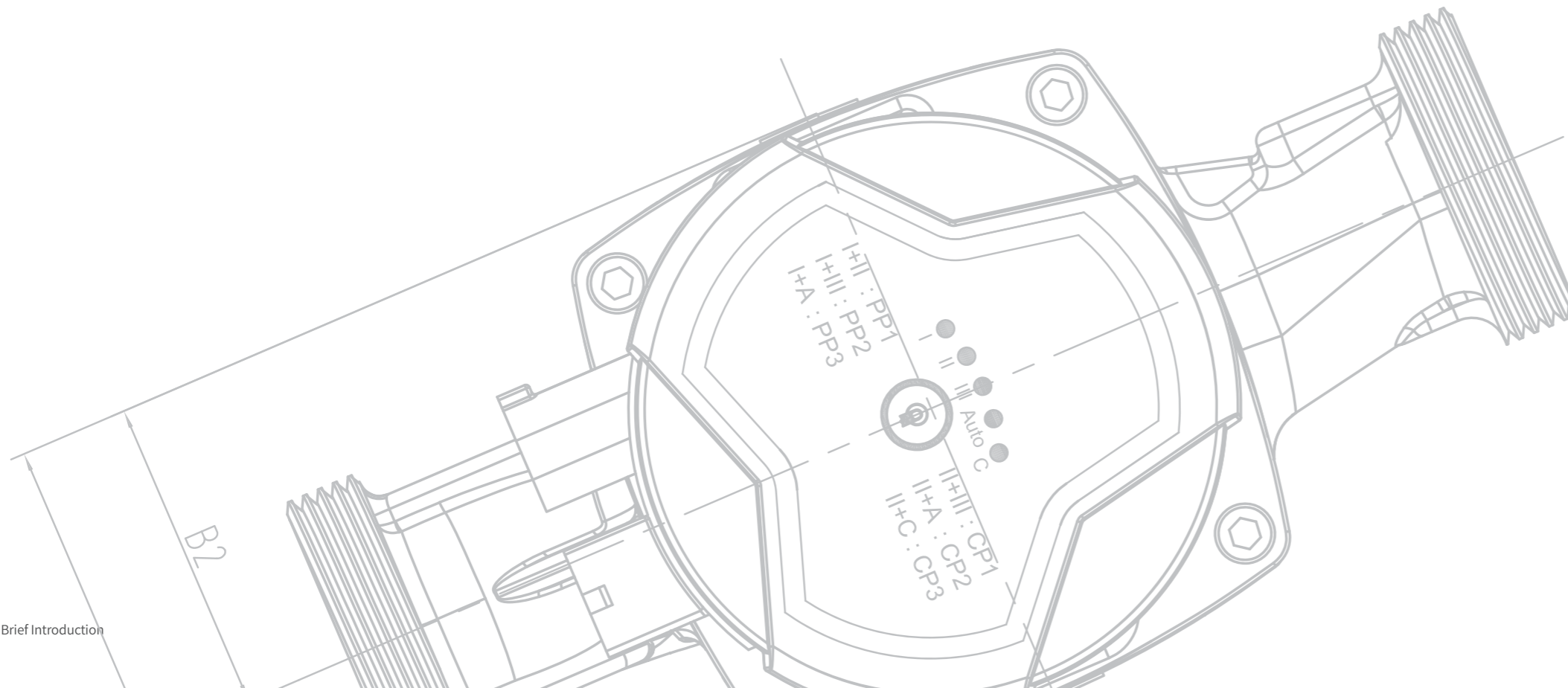

Structural Diagram

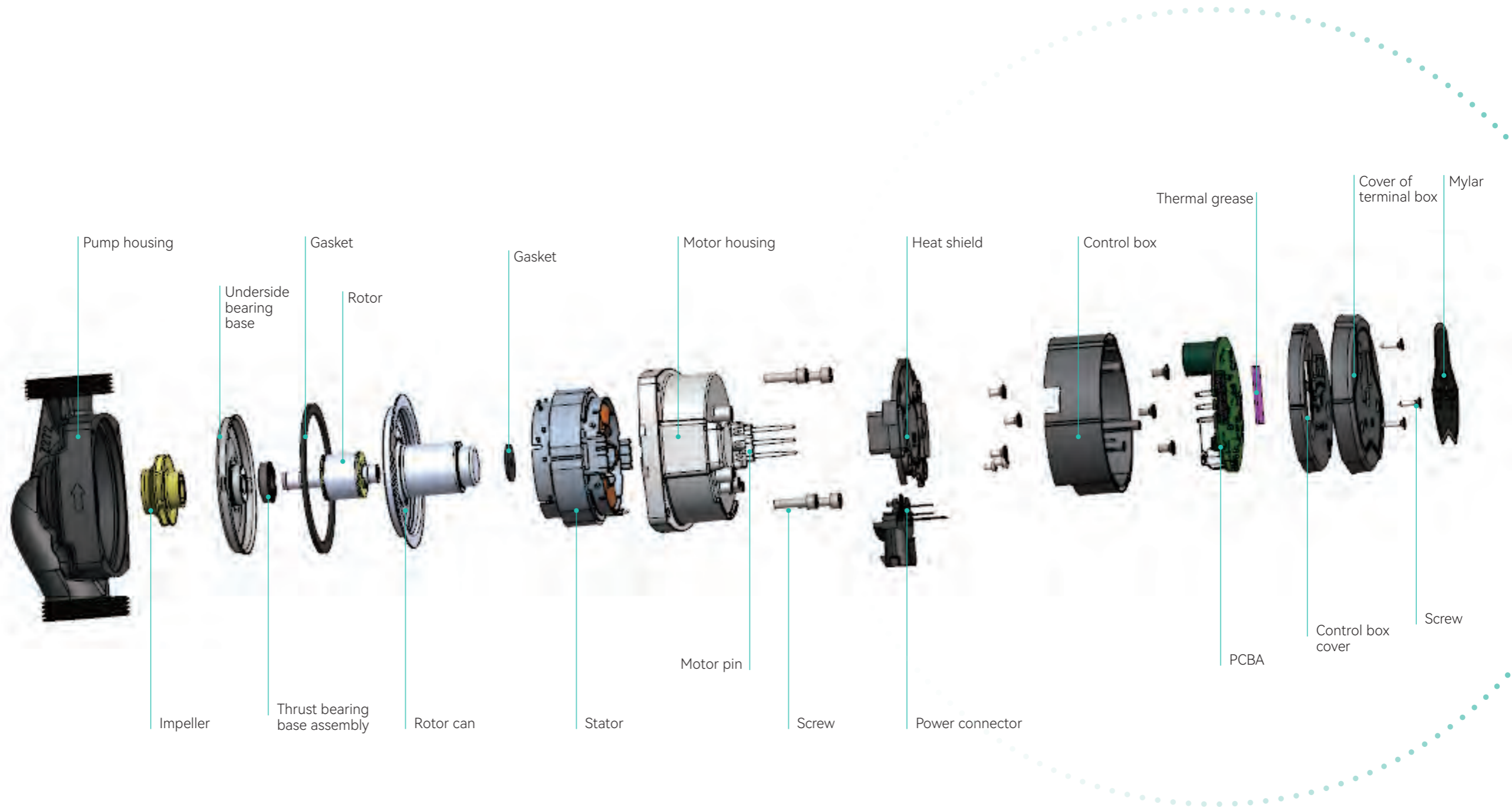

Classic S

High Efficiency Circulation Pump



Applications

1. Domestic heating and hot water supply systems
2. Air and ground source heat pump systems
3. Air-conditioning systems
4. Industrial hot water circulation systems
5. Solar thermal systems

Features and benefits

Easy installation and operation

Equipped with Self Adapting Mode(Auto Mode, Factory Setting), pump runs once the power is connected and adapts its performance according to actual system needs.

Control is effected by digital pulse-width modulation (PWM) low-voltage signal, enabling the pump to be used to meet different flow requirement in various systems.

Low noise and high comfort

Noise index: $\leq 42\text{dB(A)}$

Low energy consumption

A class energy efficiency. Power consumption lowest to 5W

Multiple protection

With over-voltage and over-current protection

Eco-Design Benchmark

EEI $\leq 0.20\text{-Part 2}$

Two versions, to meet different requirements of usages.

1. Button model, to switch modes with button
2. Rotary control model, easy operation

Quick release power plug

Start-up and stop the pump quickly.

Product photo and control modes

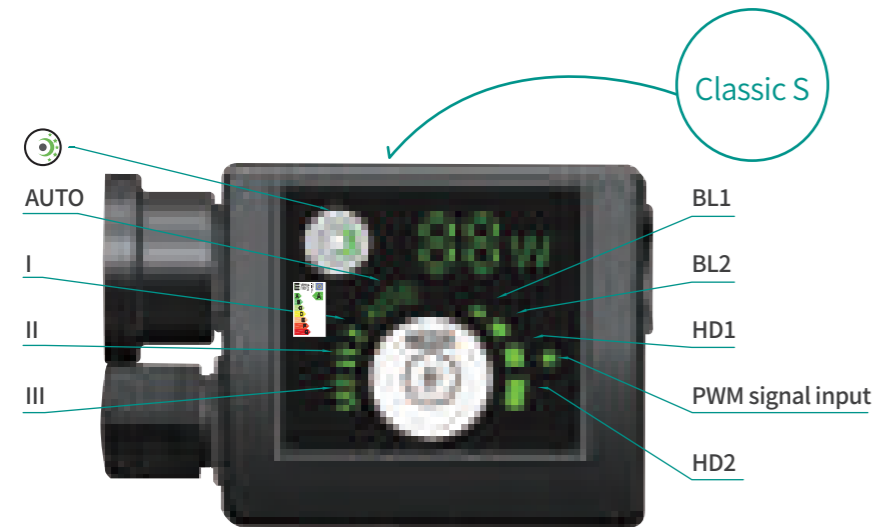

Setting	Explanation
Auto (Factory Setting)	Proportional pressure curve descending from highest to lowest
BL1	Min. proportional pressure curve
BL2	Max. proportional pressure curve
HD1	Min. constant pressure curve
HD2	Max. constant pressure curve
III	Constant Speed III
II	Constant Speed II
I	Constant Speed I
Night mode	Night mode
PWM	PWM duty cycle performance curve

Night mode

- Press button to switch between control modes,
- Press night mode button to switch to night mode.

Running light

- Switch between AUTO and Min-Max with rotary control

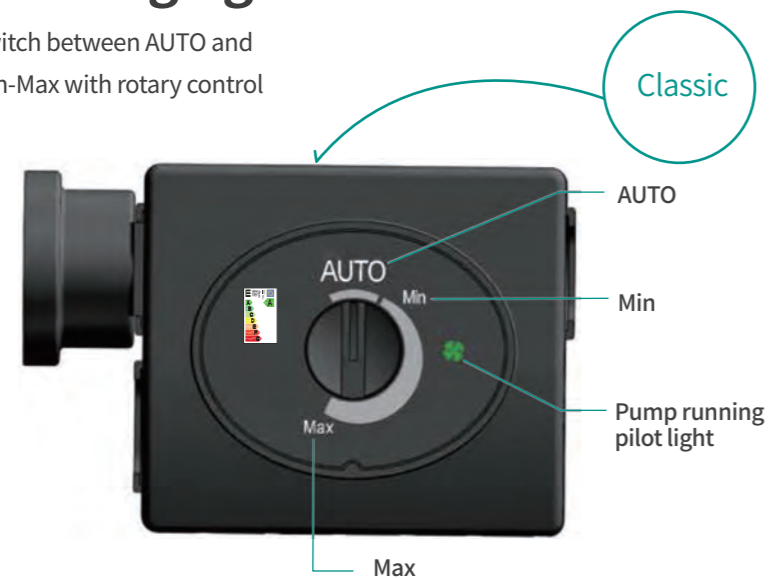

Setting	Explanation
AUTO (factory setting)	Proportional pressure curve descending from highest to lowest
Continuously viable	"Min-Max" curve

Technical parameter

Technical data

Power supply voltage	230V (+10% -15%) 50/60Hz, PE
Motor protection	No external protection required
IP class	IP42
Insulation class	H
(RH) Humidity	Max. 95%
System pressure	1.0 MPa
Compliance	CE/ GS/ EMC/ LVD/RoHS/REACH
Ambient temperature	0°C~+40°C
Temperature class	TF110
Medium temperature	+2°C~+110°C (Glycol up to 50%)

Classic S performance curve

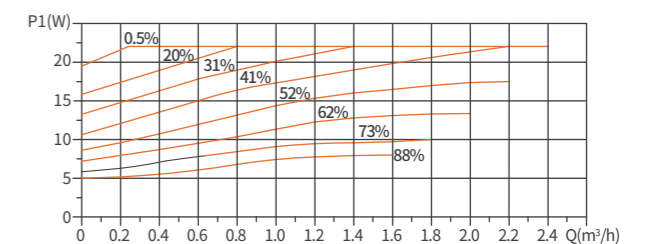
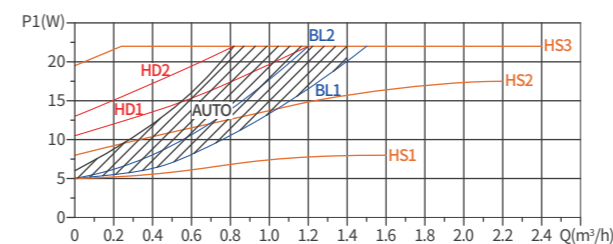
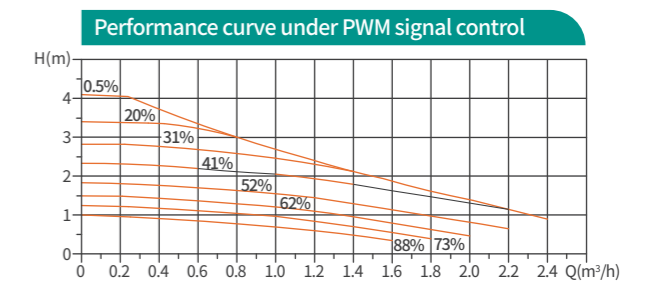
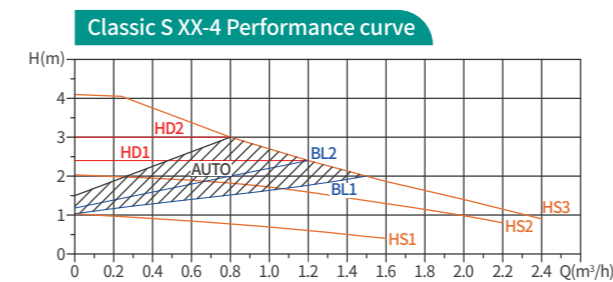

Classic performance curve

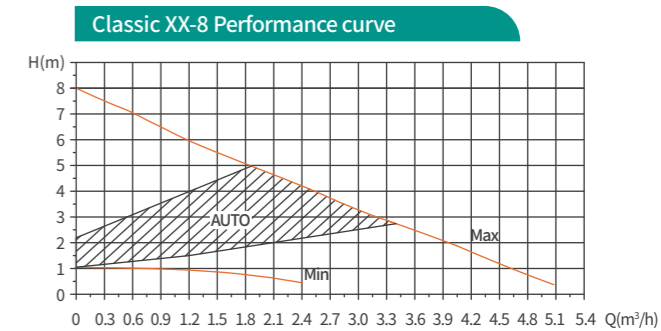
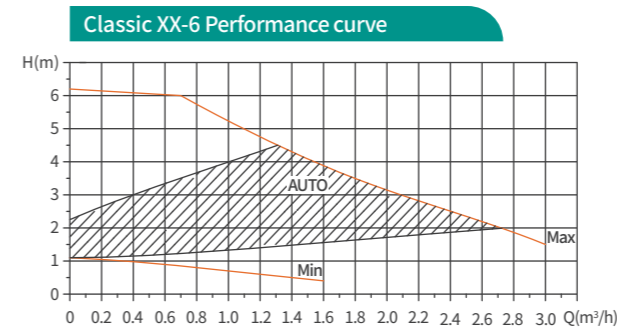
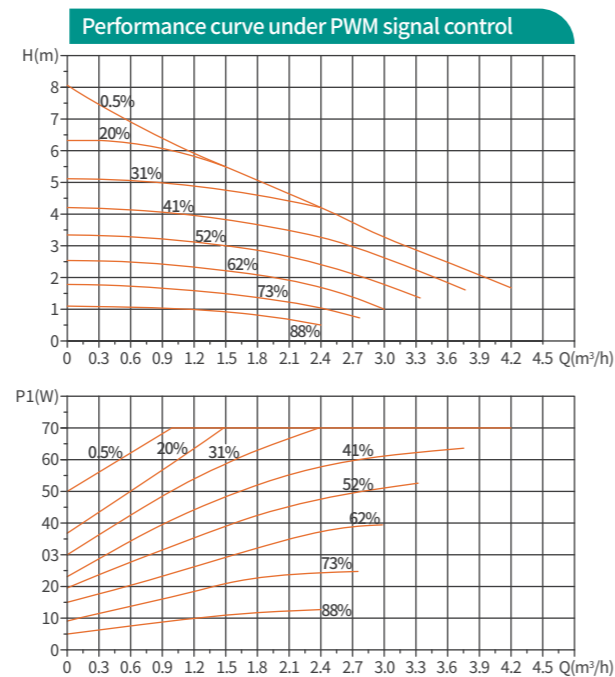
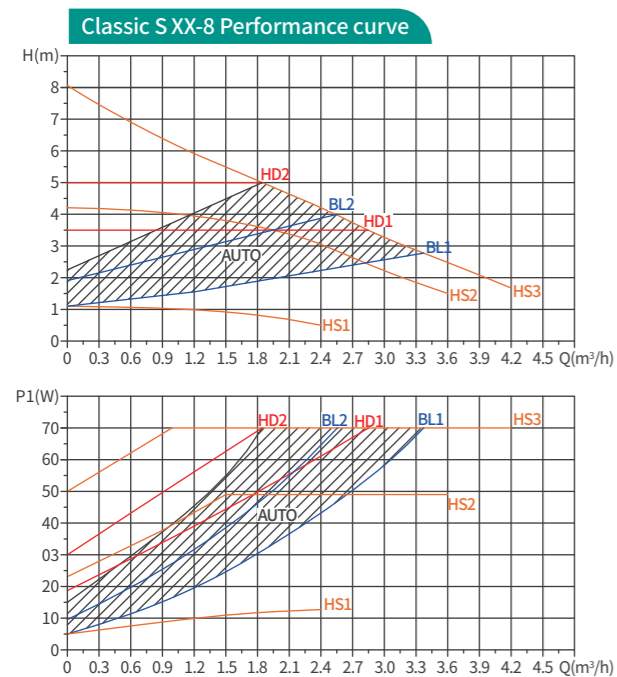
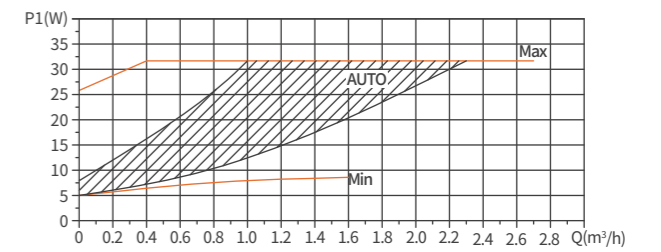
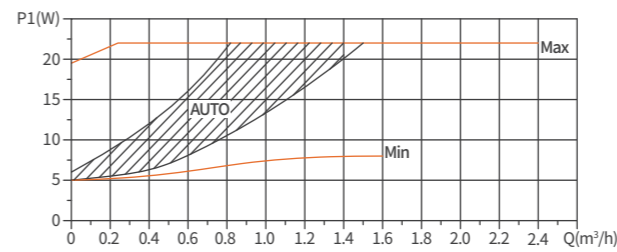
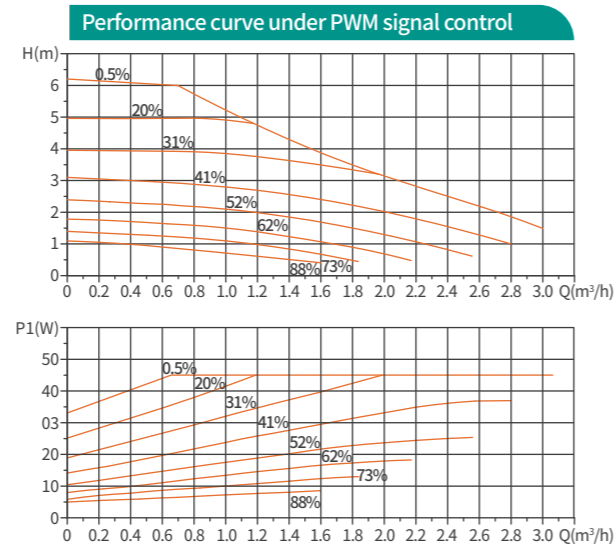
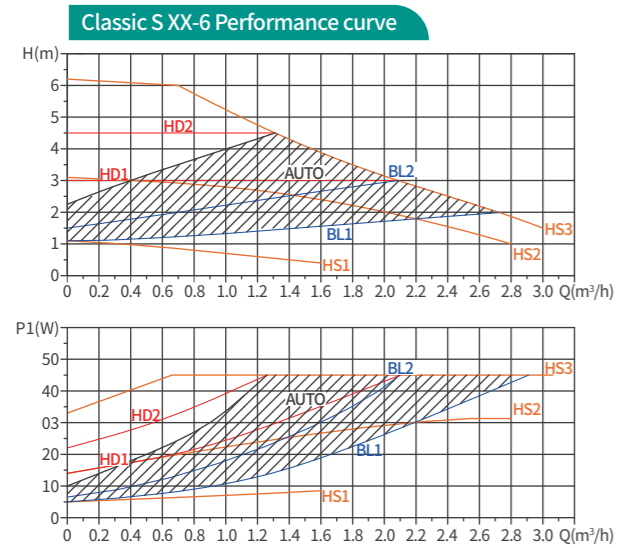
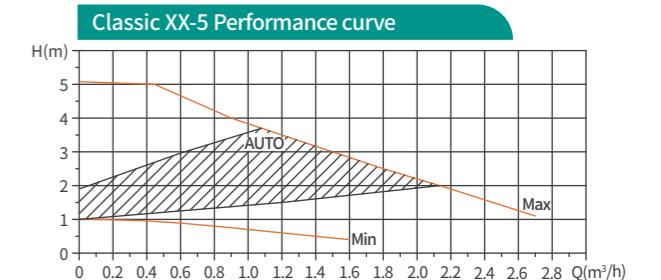
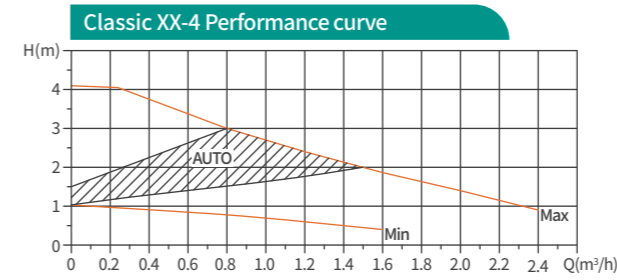
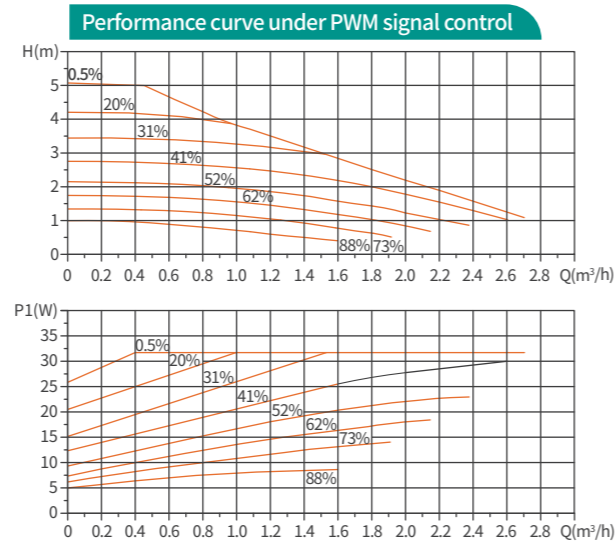
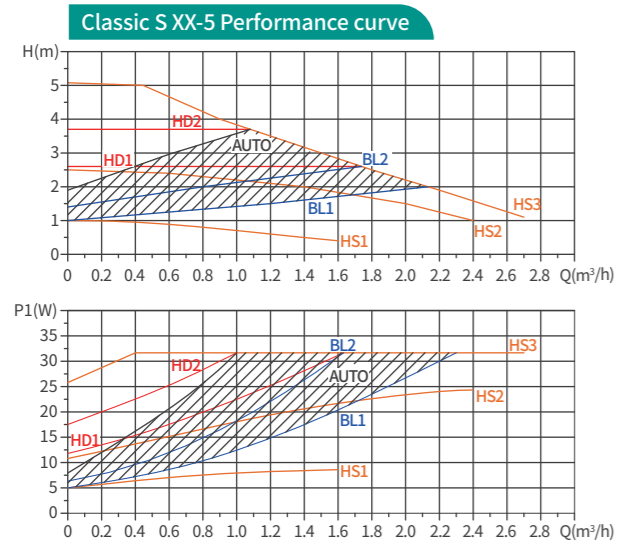

Installation drawing and performance parameter

Classic S

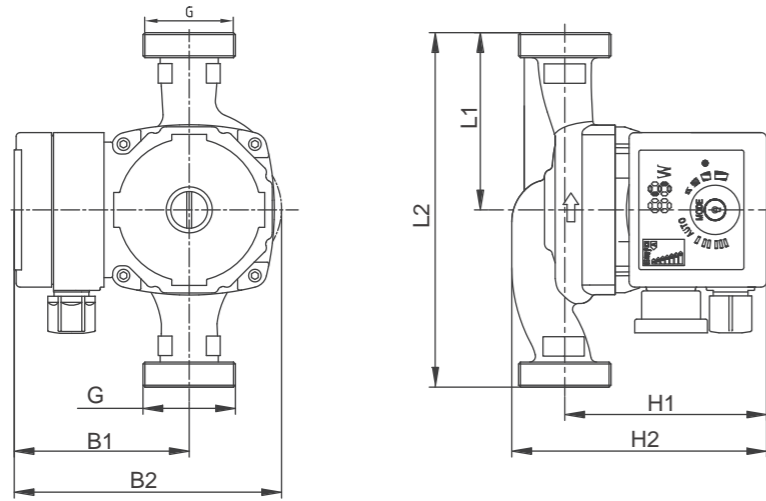

Classic

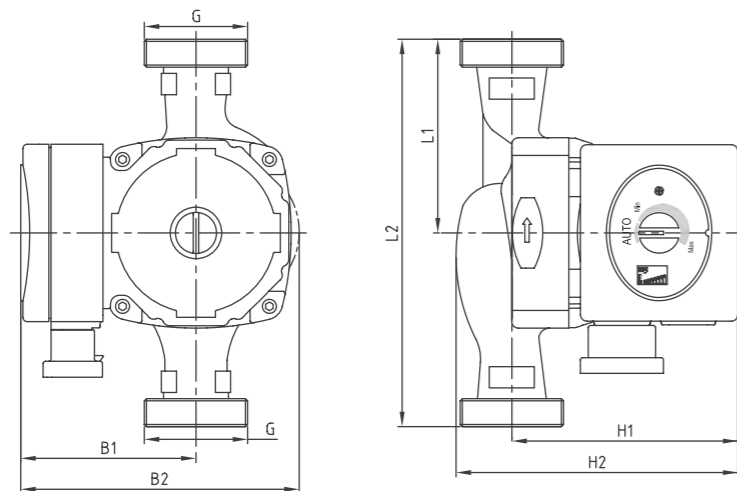

Performance parameter (Classic S & Classic)

Power (W)	Model	Max flow (m³/h)	Max Head (m)	Current (A)	Voltage/ Frequency	Pump body material				Dimensions(mm)						Package size (mm*mm*mm)		Wt.(kg)		
						230V 50/60Hz	Cast iron	Plastic	Brass	Stainless steel	L1	L2	B1	B2	H1	H2	G	Inner box	G.W.	N.W.
22	Classic S 20-4	2.3	4	0.19	230V 50/60Hz	●	●	●	●	●	65	130	82	130	103	127	1"	155x140x165	2.4	1.9
	Classic S 25-4	2.5				●	●	●	●	65	130	82	130	103	130	1½"	155x140x165	2.9	2.1	
		2.5				●	●	●	●	75	150	82	130	103	130		200x165x155	3.1	2.3	
		3.0				●	●	●	●	90	180	82	130	103	130		200x165x155	3.2	2.4	
Classic S 32-4	3.0	●	●	●	●	90	180	82	130	102	132	2"	200x165x155	3.5	2.5					
32	Classic S 20-5	2.5	5	0.27	230V 50/60Hz	●	●	●	●	●	65	130	82	130	103	127	1"	155x140x165	2.4	1.9
	Classic S 25-5	3.0				●	●	●	●	65	130	82	130	103	130	1½"	155x140x165	2.9	2.1	
		3.0				●	●	●	●	75	150	82	130	103	130		200x165x155	3.1	2.3	
		3.5				●	●	●	●	90	180	82	130	103	130		200x165x155	3.2	2.4	
Classic S 32-5	3.5	●	●	●	●	90	180	82	130	102	132	2"	200x165x155	3.5	2.5					
45	Classic S 20-6	2.8	6	0.38	230V 50/60Hz	●	●	●	●	●	65	130	82	130	103	127	1"	155x140x165	2.4	1.9
	Classic S 25-6	3.2				●	●	●	●	65	130	82	130	103	130	1½"	155x140x165	2.9	2.1	
		3.2				●	●	●	●	75	150	82	130	103	130		200x165x155	3.1	2.3	
		4.0				●	●	●	●	90	180	82	130	103	130		200x165x155	3.2	2.4	
Classic S 32-6	4.0	●	●	●	●	90	180	83	130	102	132	2"	200x165x155	3.5	2.5					
70	Classic S 20-8	3.4	8	0.52	230V 50/60Hz	●	●	●	●	●	65	130	88	136	103	127	1"	155x140x165	2.9	2.1
	Classic S 25-8	4.0				●	●	●	●	65	130	88	136	103	130	1½"	155x140x165	2.9	2.1	
		4.0				●	●	●	●	75	150	88	136	103	130		200x165x155	3.1	2.3	
		5.0				●	●	●	●	90	180	88	136	103	130		200x165x155	3.2	2.4	
Classic S 32-8	5.0	●	●	●	●	90	180	88	136	102	132	2"	200x165x155	3.5	2.5					

Classic E

High Efficiency Circulation Pump



Applications

1. Domestic heating and hot water supply systems
2. Air and ground source heat pump systems
3. Air-conditioning systems
4. Industrial hot water circulation systems
5. Solar thermal system

Features and benefits

Easy installation and operation

Equipped with Self Adapting Mode(Auto Mode, Factory Setting), pump runs once the power is connected and adapts its performance according to actual system needs.

Low noise and high comfort

Noise index: $\leq 42\text{dB(A)}$

Low energy consumption

A class energy efficiency. Power consumption lowest to 5W

Multiple protection

With over-voltage and over-current protection

Eco-Design Benchmark

$\text{EEI} \leq 0.20\text{-Part 2}$

Quick release power plug

Start-up and stop the pump quickly.

Product photo and control modes

Running lights

Switch between AUTO and Min-Max with button

Product photo and control modes

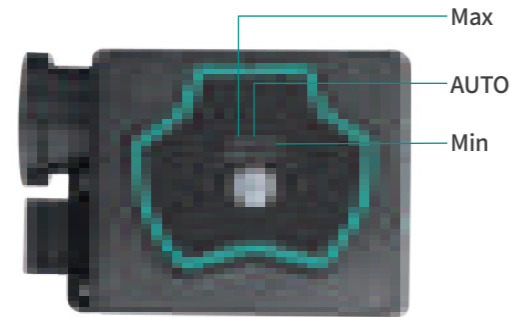

Setting	Explanation
Auto (Factory Setting)	Proportional pressure curve descending from highest to lowest
Min	Min. curve
Max	Max. curve

Technical parameter

Technical data

Power supply voltage	230V (+10% -15%) 50/60Hz, PE
Motor protection	No external protection required
IP class	IP42
Insulation class	H
(RH) Humidity	Max. 95%
System pressure	1.0 MPa
Compliance	CE/ GS/ EMC/ LVD/RoHS/REACH
Ambient temperature	0~+40°C
Temperature class	TF110
Medium temperature	+2°C~+110°C (Glycol up to 50%)

Performance curve

Classic E XX-4 Performance Curve

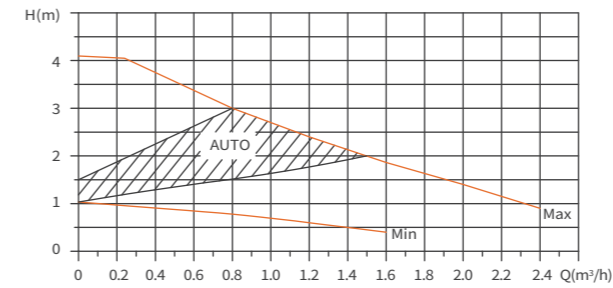

Classic E XX-5 Performance Curve

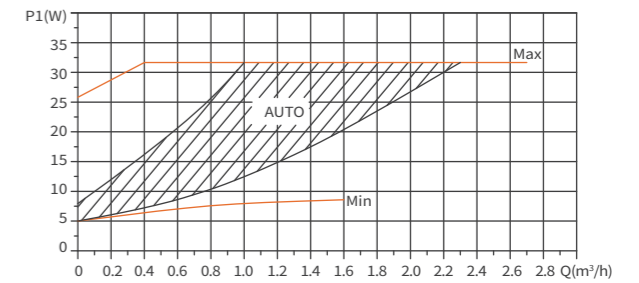
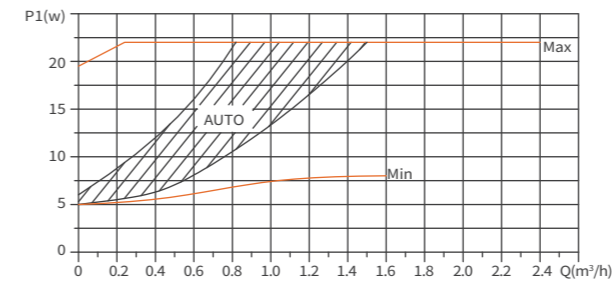
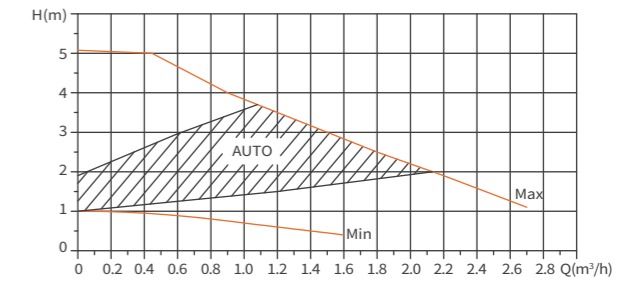

Classic E XX-6 Performance Curve

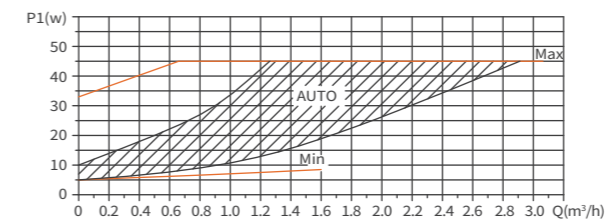
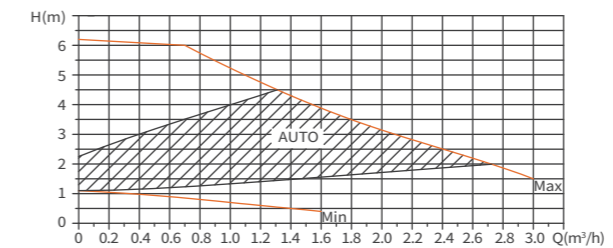

Installation drawing and performance parameter

Installation drawing

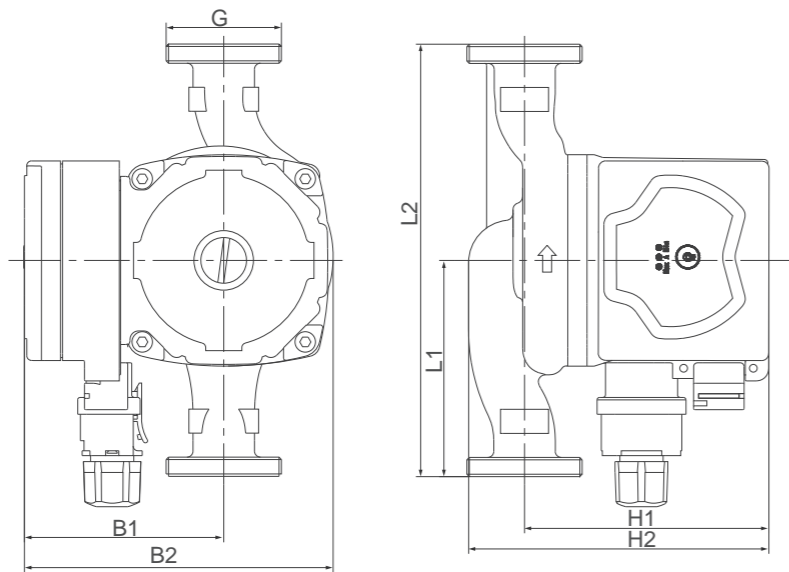

Performance parameter

Power (W)	Model	Max Flow (m³/h)	Max Head (m)	Current (A)	Voltage/ Frequency		Pump body material				Dimensions(mm)							Package size (mm*mm*mm)			Wt.(kg)	
					230V	50/60Hz	Cast iron	Plastic	Brass	Stainless steel	L1	L2	B1	B2	H1	H2	G	Inner box	G.W.	N.W.		
22	Classic E 20-4	2.3	4	0.19	●	●	●	●	●	65	130	82	130	103	127	1"	155x140x165	2.4	1.9			
	Classic E 25-4	2.5			●	●	●	●	65	130	82	130	103	130	1½"	155x140x165	2.9	2.1				
		75			150	82	130	103	130	200x165x155	3.1	2.3										
		90			180	82	130	103	130	200x165x155	3.2	2.4										
Classic E 32-4	3.0	●	●	●	●	90	180	82	130	102	132	2"	200x165x155	3.5	2.5							
32	Classic E 20-5	2.5	5	0.27	●	●	●	●	65	130	82	130	103	127	1"	155x140x165	2.4	1.9				
	Classic E 25-5	3.0			●	●	●	●	65	130	82	130	103	130	1½"	155x140x165	2.9	2.1				
		75			150	82	130	103	130	200x165x155	3.1	2.3										
		90			180	82	130	103	130	200x165x155	3.2	2.4										
Classic E 32-5	3.5	●	●	●	●	90	180	82	130	102	132	2"	200x165x155	3.5	2.5							
45	Classic E 20-6	2.8	6	0.38	●	●	●	●	65	130	82	130	103	127	1"	155x140x165	2.4	1.9				
	Classic E 25-6	3.2			●	●	●	●	65	130	82	130	103	130	1½"	155x140x165	2.9	2.1				
		75			150	82	130	103	130	200x165x155	3.1	2.3										
		90			180	82	130	103	130	200x165x155	3.2	2.4										
Classic E 32-6	4.0	●	●	●	●	90	180	82	130	102	132	2"	200x165x155	3.5	2.5							

Master D

High Efficiency Circulation Pump



Applications

1. Domestic heating and hot water supply systems
2. Air and ground source heat pump systems
3. Air-conditioning systems
4. Industrial hot water circulation systems
5. Solar thermal system

Features and benefits

Easy installation and operation

Equipped with Self Adapting Mode(Auto Mode, Factory Setting), pump runs once the power is connected and adapts its performance according to actual system needs.

Control is effected by digital pulse-width modulation (PWM) low-voltage signal, enabling the pump to be used to meet different flow requirement in various systems.

Low noise and high comfort

Noise index: $\leq 42\text{dB(A)}$

Low energy consumption

A class energy efficiency. Power consumption lowest to 5W

Multiple protection

With over-voltage and over-current protection

Eco-Design Benchmark

$\text{EEI} \leq 0.20$ -Part 2

Quick release power plug

Start-up and stop the pump quickly.

Product photo and control modes



◀ Press button to switch between modes.
(AUTO, PP1, PP2, PP3, CP1, CP2, CP3, CS1, CS2, CS3, P1, P2, MAX)

Keystrokes number of times	Lighting Area	clarification	icon
0	AUTO	Auto-adaptation	
1	PP1	Proportional pressure low speed	
2	PP2	Proportional pressure medium speed	
3	PP3	Proportional Pressure High Speed	
4	CP1	Constant pressure low speed	
5	CP2	Constant pressure medium speed	
6	CP3	Constant pressure high speed	
7	CS1	Constant speed low speed	
8	CS2	Constant velocity medium speed	
9	CS3	Constant speed high speed	
10	PWM	Duty cycle and rotational velocity curve	

Technical parameter

Technical data

Power supply voltage	230V (+10% -15%) 50/60Hz, PE
Motor protection	No external protection required
IP class	IP44
Insulation class	H
Humidity (RH)	Max 95%
System pressure	1.0 MPa
Compliance	CE/ GS/ EMC/ LVD/RoHS/REACH
Ambient temperature	-30°C~70°C
Temperature class	TF110
Medium temperature	-20°C~110°C(Glycol up to 50%)

Performance curve

Master D XX-4 Performance curve

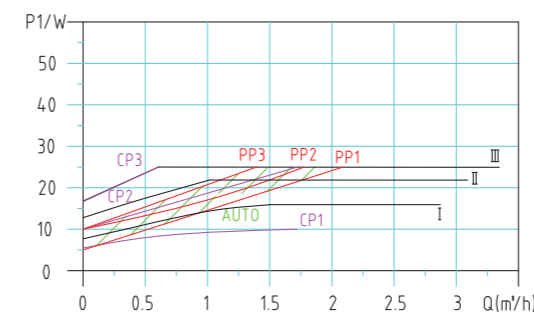
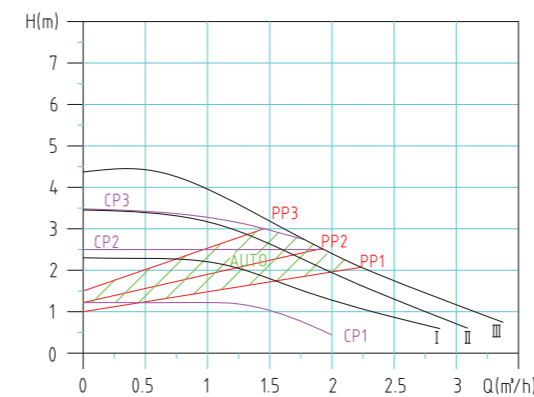

Master D XX-5 Performance curve

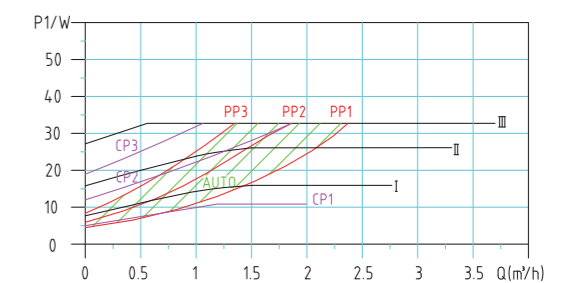
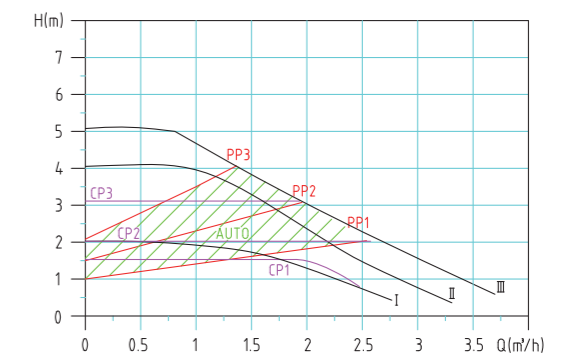

Installation drawing and performance parameter

Installation drawing

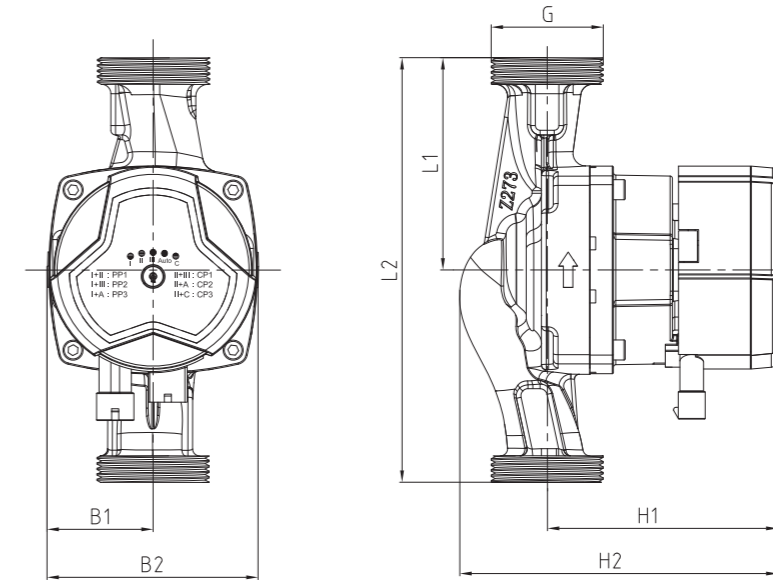

Performance parameter

Power (W)	Model	Max. Flow (m ³ /h)	Max. Head (m)	Current (A)	Voltage/Frequency				Material of pump housing				Dimension (mm)						Package size (mm*mm*mm)		Wt. (kg)	
					230V	50/60Hz	Cast Iron	Plastic	Copper	Stainless Steel	L1	L2	B1	B2	H1	H2	G	Inner box	G.W.	N.W.		
25	Master D 20-4	2.6	4	0.25	●	●	●	●	65	130	45	90	90	135	1"	155x140x165	2.1	1.6				
	Master D 25-4	2.8			●	●	●	●	65	130	45	90	90	135	1 1/2"	155x140x165	2.3	1.8				
	Master D 32-4	3.4			●	●	●	●	90	180	45	90	90	135	2"	200x165x155	2.5	1.9				
33	Master D 20-5	2.8	5	0.30	●	●	●	●	65	130	45	90	90	135	1"	155x140x165	2.1	1.6				
	Master D 25-5	3.0			●	●	●	●	65	130	45	90	90	135	1 1/2"	155x140x165	2.3	1.8				
	Master D 32-5	3.6			●	●	●	●	90	180	45	90	90	135	2"	200x165x155	2.5	1.9				
39	Master D 20-6	3.0	6	0.35	●	●	●	●	65	130	45	90	90	135	1"	155x140x165	2.1	1.6				
	Master D 25-6	3.2			●	●	●	●	65	130	45	90	90	135	1 1/2"	155x140x165	2.3	1.8				
	Master D 32-6	3.8			●	●	●	●	90	180	45	90	90	135	2"	200x165x155	2.5	1.9				
52	Master D 20-7	3.4	7	0.45	●	●	●	●	65	130	45	90	90	135	1"	155x140x165	2.1	1.6				
	Master D 25-7	3.6			●	●	●	●	65	130	45	90	90	135	1 1/2"	155x140x165	2.3	1.8				
	Master D 32-7	4.2			●	●	●	●	90	180	45	90	90	135	2"	200x165x155	2.5	1.9				
60	Master D 20-7.5	3.5	7.5	0.50	●	●	●	●	65	130	45	90	90	135	1"	155x140x165	2.1	1.6				
	Master D 25-7.5	3.8			●	●	●	●	65	130	45	90	90	135	1 1/2"	155x140x165	2.3	1.8				
	Master D 32-7.5	4.4			●	●	●	●	90	180	45	90	90	135	2"	200x165x155	2.5	1.9				
70	Master D 20-8	3.6	8	0.55	●	●	●	●	65	130	45	90	90	135	1"	155x140x165	2.1	1.6				
	Master D 25-8	3.9			●	●	●	●	65	130	45	90	90	135	1 1/2"	155x140x165	2.3	1.8				
	Master D 32-8	4.7			●	●	●	●	90	180	45	90	90	135	2"	200x165x155	2.5	1.9				

Master D XX-6 Performance curve

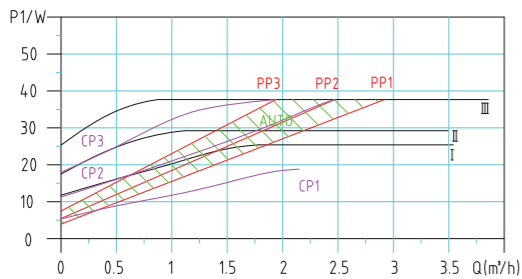
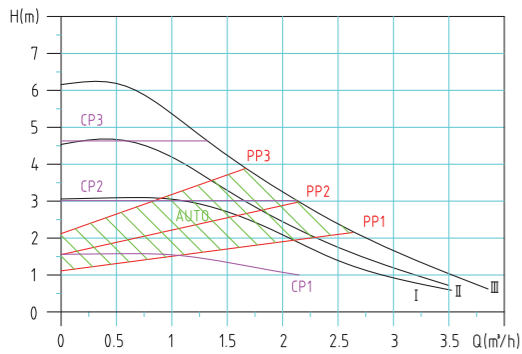

Master D XX-7 Performance curve

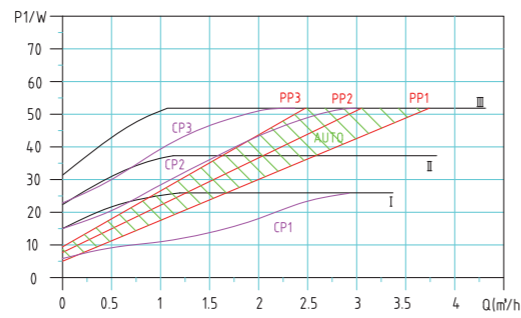
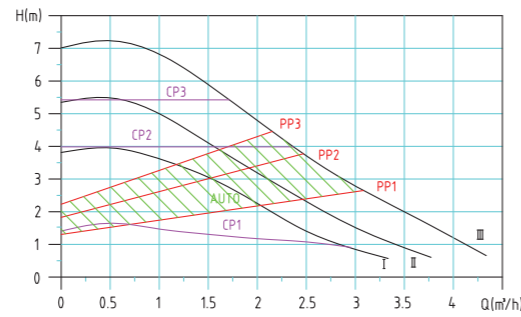

Master D XX-7.5 Performance curve

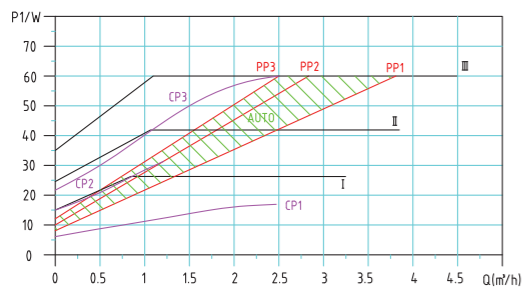
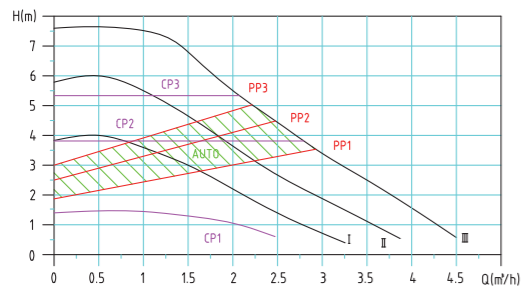

Master D XX-8 Performance curve

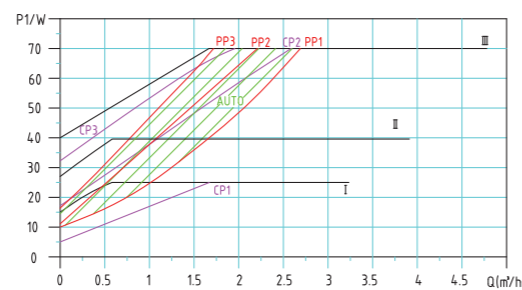
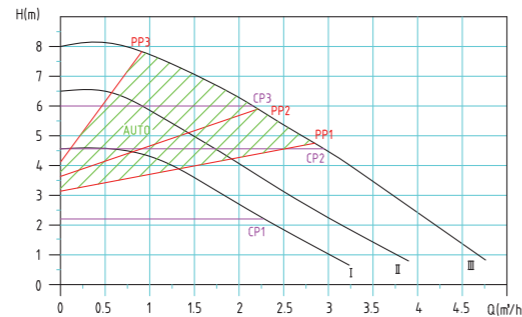

LPA

High Efficiency Circulation Pump



Applications

1. Domestic heating and hot water supply systems
2. Air and ground source heat pump systems
3. Air-conditioning systems
4. Industrial hot water circulation systems
5. Solar thermal system

Features and benefits

Easy installation and operation

Equipped with Self Adapting Mode(Auto Mode, Factory Setting), pump runs once the power is connected and adapts its performance according to actual system needs.

Low noise and high comfort

Noise index: $\leq 42\text{dB(A)}$

Low energy consumption

A class energy efficiency. Power consumption lowest to 5W

Multiple protection

With over-voltage and over-current protection

Eco-Design Benchmark

$\text{EEI} \leq 0.20$ -Part 2

Quick release power plug

Start-up and stop the pump quickly.

Product photo and control modes



Setting	Explanation
AUTO (factory setting)	Proportional pressure curve descending from highest to lowest
BL1	Min.proportional pressure curve
BL2	Max.proportional pressure curve
HD1	Min.constant pressure curve
HD2	Max.constant pressure curve
III	Constant Speed III
II	Constant Speed II
I	Constant Speed I

◀ (HS1, HS2, HS3, AUTO, BL1, BL2, HD1, HD2)
Press button to switch between different control modes.

Technical parameter

Technical data

Power supply voltage	230V (+10% -15%) 50/60Hz, PE
Motor protection	No external protection required
IP class	IP44
Insulation class	H
(RH) Humidity	Max. 95%
System pressure	1.0 MPa
Compliance	CE/ GS/ EMC/ LVD/RoHS/REACH
Environment temperature	0~+40°C
Temperature class	TF110
Liquid temperature	+2°C~+110°C(Glycol up to 50%)

Performance curve

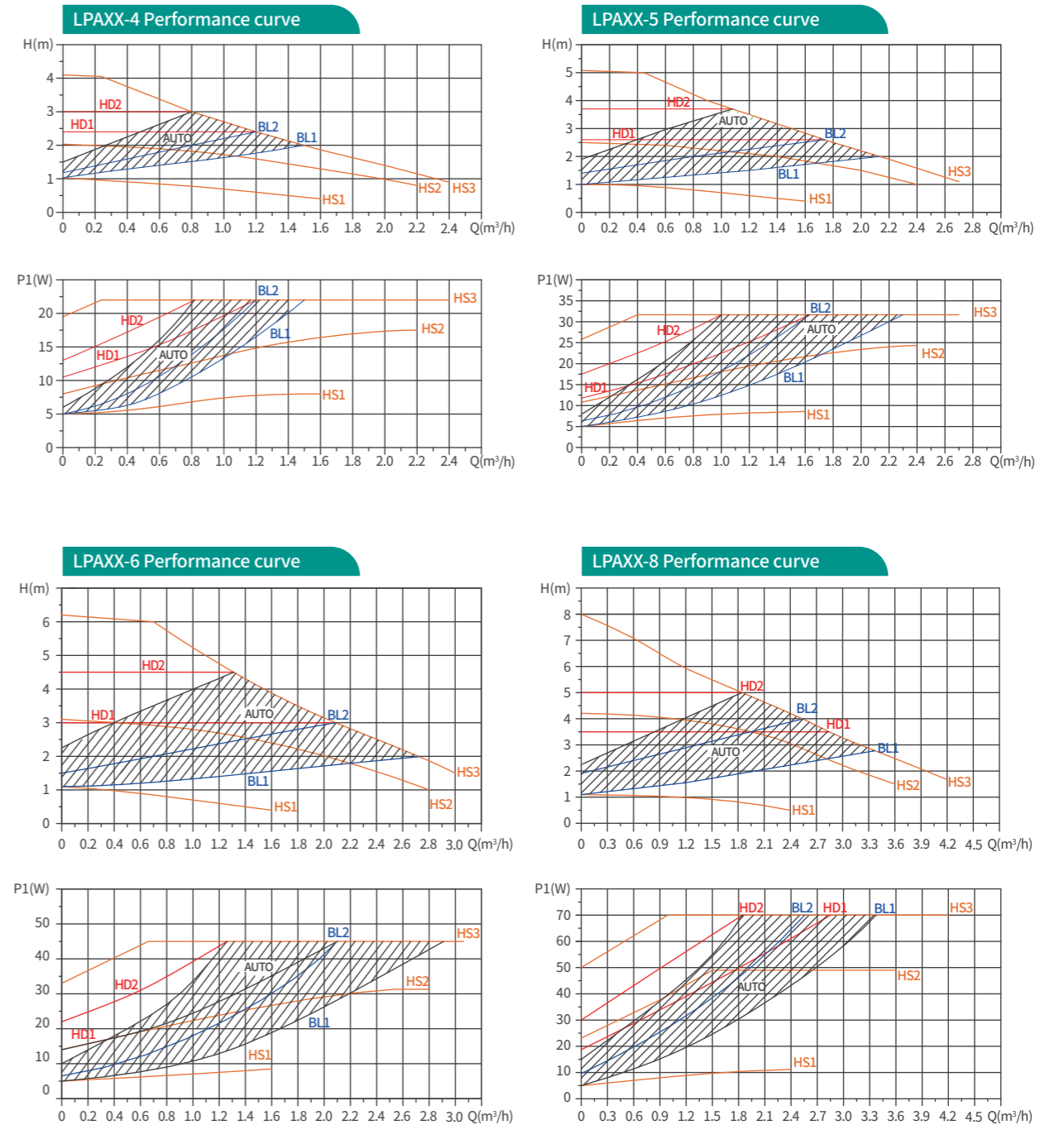

Installation drawing and performance parameter

Installation drawing

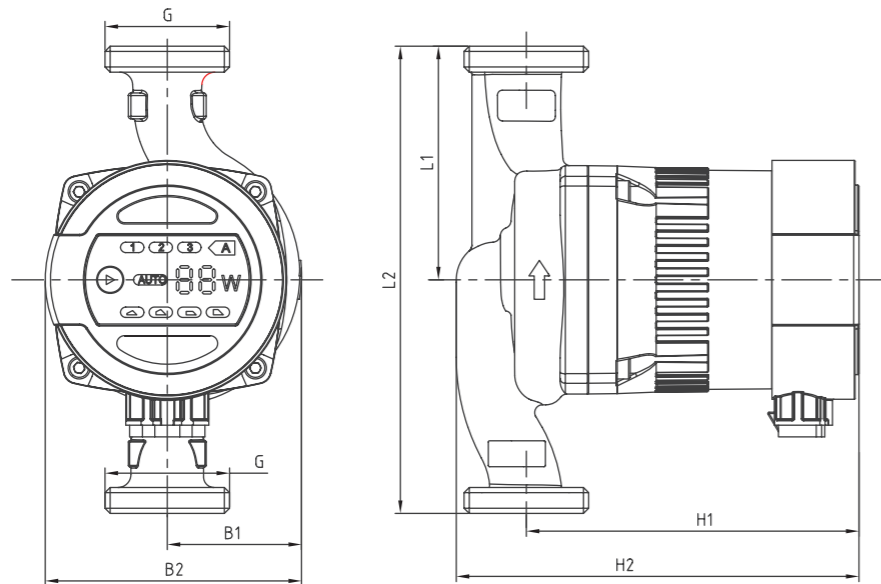

Performance parameter

Power (W)	Model	Max Flow (m³/h)	Max Head (m)	Current (A)	Voltage/ Frequency		Pump body material				Dimensions(mm)						Package size (mm*mm*mm)		Wt.(kg)	
					230V	50/60Hz	Cast iron	Plastic	Brass	Stainless steel	L1	L2	B1	B2	H1	H2	G	Inner box	G.W.	N.W.
22	LPA20-4	2.3	4	0.19	●	●	●	●	●	65	130	51	98	133	153	1"	190x170x150	2.4	1.9	
	LPA25-4	2.5			●	●	●	●	65	130	52	99	128	156	1½"	190x170x150	2.9	2.1		
		2.5			●	●	●	●	75	150	49	96	131	155		190x170x200	3.1	2.3		
		2.5			●	●	●	●	90	180	52	99	128	156		190x170x200	3.2	2.4		
LPA32-4	3.0	●	●	●	●	90	180	52	99	128	156	2"	190x170x200	3.5	2.5					
32	LPA20-5	2.5	5	0.27	●	●	●	●	●	65	130	52	99	133	153	1"	190x170x150	2.4	1.9	
	LPA25-5	3.0			●	●	●	●	65	130	52	99	128	156	1½"	190x170x150	2.9	2.1		
		3.0			●	●	●	●	75	150	49	96	131	155		190x170x200	3.1	2.3		
		3.0			●	●	●	●	90	180	52	99	128	156		190x170x200	3.2	2.4		
LPA32-5	3.5	●	●	●	●	90	180	52	99	128	156	2"	190x170x200	3.5	2.5					
45	LPA20-6	2.8	6	0.38	●	●	●	●	●	65	130	52	99	133	153	1"	190x170x150	2.4	1.9	
	LPA25-6	3.2			●	●	●	●	65	130	52	99	128	156	1½"	190x170x150	2.9	2.1		
		3.2			●	●	●	●	75	150	49	96	131	155		190x170x200	3.1	2.3		
		3.2			●	●	●	●	90	180	52	99	128	156		190x170x200	3.2	2.4		
LPA32-6	4.0	●	●	●	●	90	180	52	99	128	156	2"	190x170x200	3.5	2.5					
70	LPA20-8	3.4	8	0.52	●	●	●	●	●	65	130	52	98	133	153	1"	190x170x150	2.4	1.9	
	LPA25-8	4.0			●	●	●	●	65	130	52	99	128	156	1½"	190x170x150	2.9	2.1		
		4.0			●	●	●	●	75	150	49	96	131	155		190x170x200	3.1	2.3		
		4.0			●	●	●	●	90	180	52	99	128	156		190x170x200	3.2	2.4		
LPA32-8	5.0	●	●	●	●	90	180	52	99	128	156	2"	190x170x200	3.5	2.5					

Mega

High Efficiency Circulation Pump



Applications

1. Domestic heating and hot water supply systems
2. Air and ground source heat pump systems
3. Air-conditioning systems
4. Industrial hot water circulation systems
5. Solar thermal system

Features and benefits

Easy installation and operation

Equipped with Self Adapting Mode(Auto Mode, Factory Setting), pump runs once the power is connected and adapts its performance according to actual system needs.

Control is effected by digital pulse-width modulation (PWM) low-voltage signal, enabling pump to be used to meet different flow requirement in various systems.

Low noise and high comfort

Noise index: $\leq 42\text{dB(A)}$

Low energy consumption

A class energy efficiency. Power consumption lowest to 6W

Multiple protection

With over-voltage and over-current protection.

Eco-Design Benchmark

$\text{EEI} \leq 0.23\text{-Part 2}$

Quick release power plug

Start-up and stop the pump quickly.

Product photo and control modes

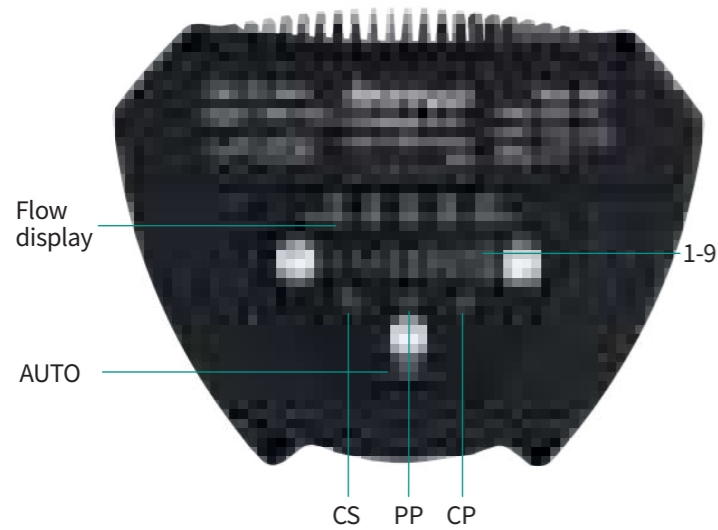

Setting	Explanation
AUTO (factory setting)	Running with in Defined Range
PP	Proportional pressure curve
CP	Constant pressure curve
CS	Constant speed curve

◀ Press button to switch between different control modes and increase or decrease the setting with the buttons on left and right side.

Performance curve

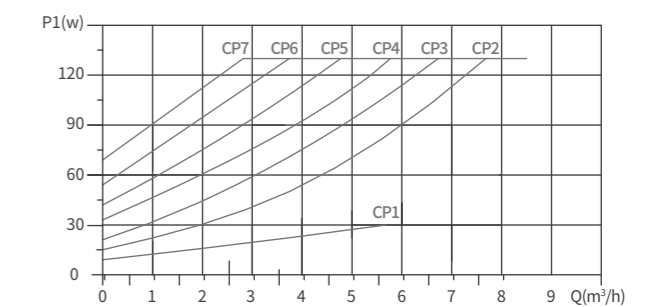
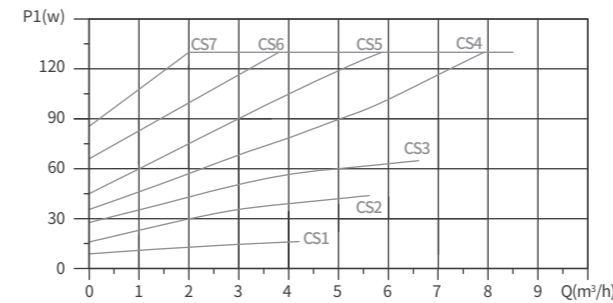
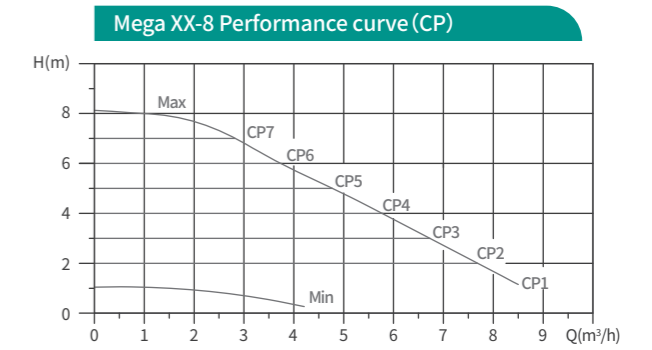
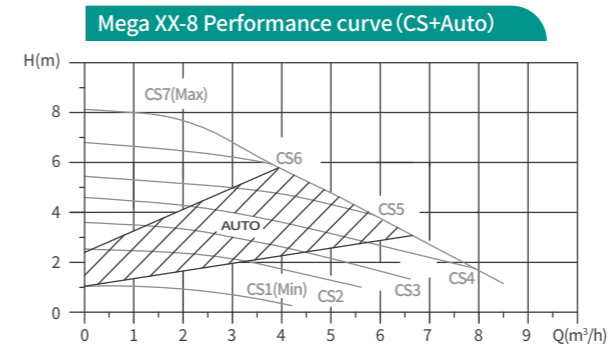

Technical parameter

Technical data

Power supply voltage	230V (+10% -15%) 50/60Hz, PE
Motor protection	No external protection required
IP class	IP44
Insulation class	H
(RH) Humidity	Max. 95%
System pressure	1.0 MPa
Compliance	CE/ GS/ EMC/ LVD/RoHS/REACH
Ambient temperature	0°C~+40°C
Temperature class	TF110
Medium temperature	+2°C~+110°C(Glycol up to 50%)

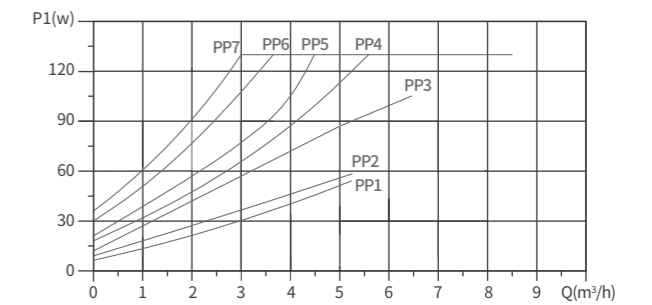
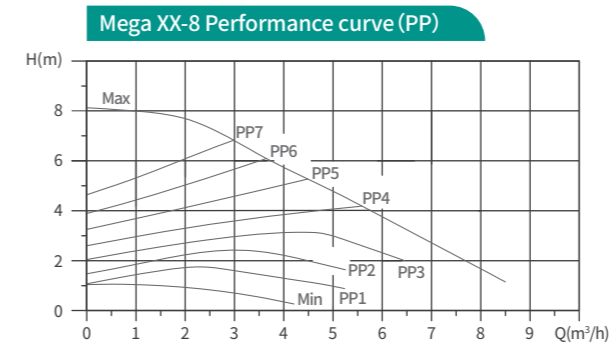

Installation drawing and performance parameter

Installation drawing—Mega (DN25/DN32)

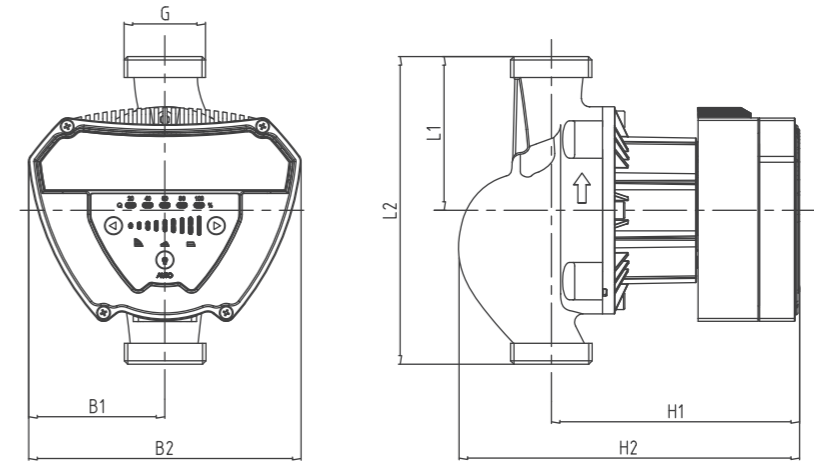

Mega XX-10 Performance curve (CS+Auto)

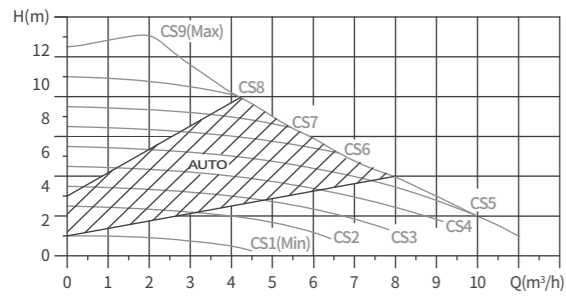

Mega XX-10 Performance curve (CP)

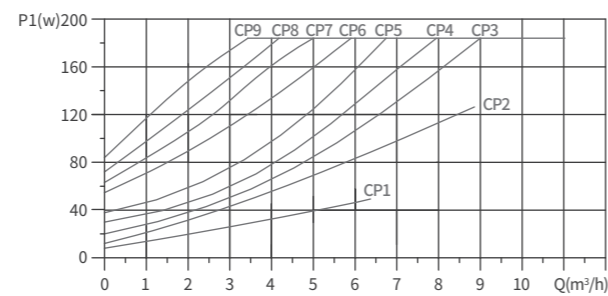
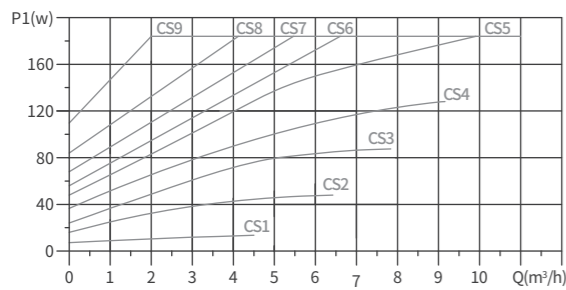
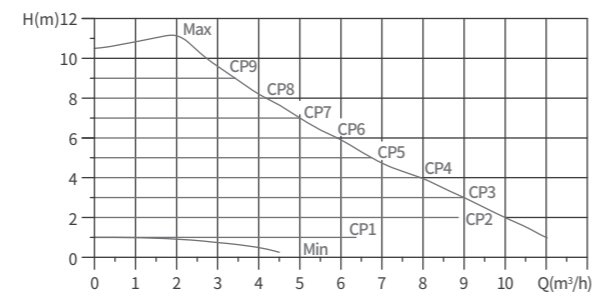

Mega XX-10 Performance curve (PP)

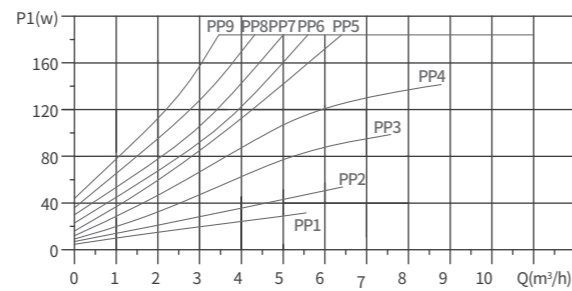
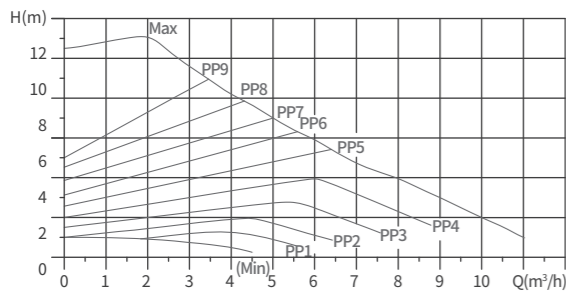

Model	Material of pump body		Dimension(mm)							Package size (mm*mm*mm)	Wt.(kg)	
	Cast iron	Stainless Steel	L1	L2	B1	B2	H1	H2	G	Inner box	G.W.	N.W.
Mega 25-8	●	●	90	180	80	160	140	199	1½"	235x180x200	5.0	4.5
Mega 32-8	●		90	180	80	160	140	199	2"	235x180x200	5.5	5.0
Mega 25-10	●	●	90	180	80	160	140	199	1½"	235x180x200	5.0	4.5
Mega 32-10	●		90	180	80	160	140	199	2"	235x180x200	5.5	5.0

Installation drawing—Mega F

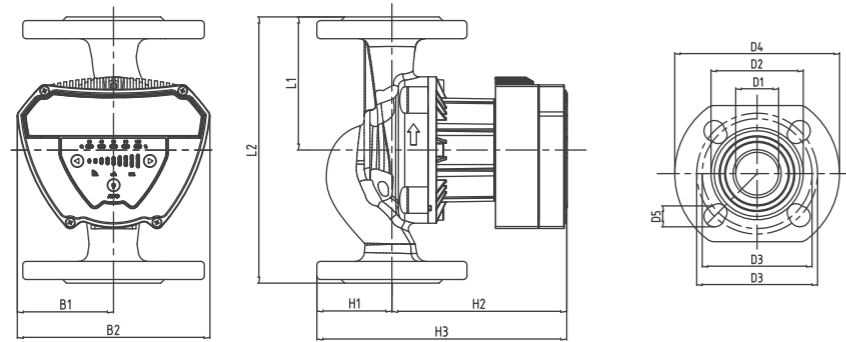

Model	Pump body material	Dimensions(mm)												Package size (mm*mm*mm)		Wt.(kg)	
	Cast iron	L1	L2	B1	B2	H1	H2	H3	D1	D2	D3	D4	D5	Inner box	G.W.	N.W.	
Mega 40-8F	●	110	220	80	160	62	144	206	40	84	100/110	150	19	245x210x245	10.0	7.6	
Mega 40-10F	●	110	220	80	160	62	144	206	40	84	100/110	150	19	245x210x245	10.0	7.6	

Performance parameter

Model	Max. Flow (m³/h)	Max. Head (m)	Power(W)		Current(A)		Voltage/Frequency (V/Hz)
			Min.	Max.	Min.	Max.	
Mega 25-8	6.5	8	8	130	0.08	0.9	230V 50/60Hz
Mega 25-10	7	10	10	185	0.1	1.25	
Mega 25-8N	6.5	8	8	130	0.08	0.9	
Mega 25-10N	7	10	10	185	0.1	1.25	
Mega 32-8	8	8	8	130	0.08	0.9	
Mega 32-10	10	10	10	185	0.1	1.25	
Mega 40-8F	8.5	8	8	130	0.08	0.9	
Mega 40-10F	10	10	10	185	0.1	1.25	

Instant S

High Efficiency Circulation Pump



Applications

1. Domestic heating and hot water circulation systems
2. Hot water heater circulation systems

Features and benefits

Easy installation and operation

Equipped with Self Adapting mode AUTO (default setting), pump runs once the power is connected and adapts its performance according to actual system needs.

Equipped with external temperature control, timing and pipeline flushing function.

Low noise and high comfort

Noise index: $\leq 42\text{dB(A)}$

Low energy consumption

Power consumption lowest to 5W

Multiple protection

With over-current protection

Quick release power plug

Start-up and stop the pump quickly.

Product photo and control modes

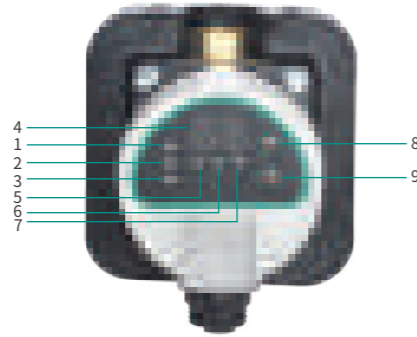

Position	Descriptions
1	Indicating constant speed running mode
2	Indicating Auto operation mode
3	Indicating temperature control mode
4	1. Power indicated 2. running (or stop) time indicated in timing mode
5	Running (or stop) hours set in timing mode for display
6	Running (or stop) minutes set in timing mode for display
7	Power unit shown under normal operation
8	1. Switch on various running modes 2. Increasing time in timing mode
9	Decreasing time in timing mode

◀ Press 8 and 9 button to switch between different control modes.

Technical parameter

Technical data

Power supply voltage	230V (+10% -15%) 50/60Hz, PE
Motor protection	No external protection required
IP class	IP42
Insulation class	F
Humidity (RH)	Max 95%
System pressure	1.0 MPa
Compliance	CE/ GS/ EMC/ LVD/RoHS/REACH
Ambient temperature	0°C~+40°C
Temperature class	TF95
Medium temperature	+2°C~+110°C(Glycol up to 50%)

Performance curve

Constant speed mode performance curve

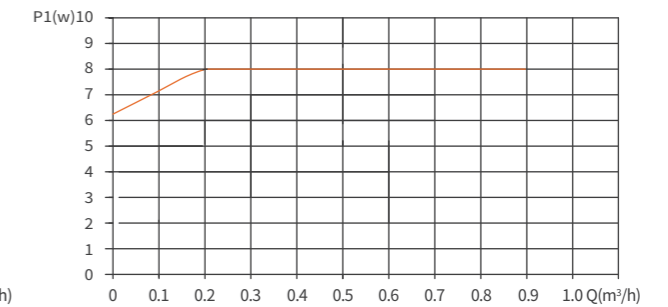
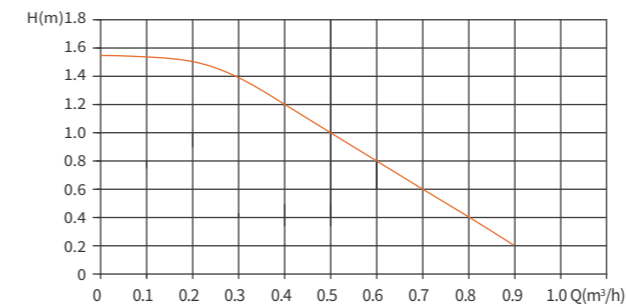

Installation drawing and performance parameter

Installation drawing

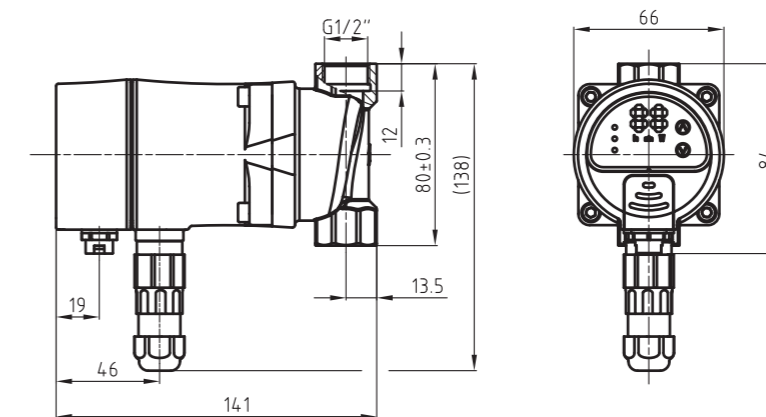

Performance parameter

Power (W)	Model	Max. Flow (m³/h)	Voltage/Frequency		Material	Control Mode of Motor Pump					Package size (mmxmmxmm)		Wt.(kg)	
			230V	50/60Hz		Constant speed running mode	Auto operation mode	Temperature Control mode	Timing mode	Flushing Function	Inner box	G.W.	N.W.	
8	Instant S	0.9	●	●	●	●	●	●	●	●	180x115x150	1.2	1.0	

Instant

High Efficiency Circulation Pump



Applications

1. Domestic heating and hot water circulation systems
2. Hot water heater circulation systems

Features and benefits

Easy installation and operation

Pump runs once the power is connected and works with maximal rotation speed all the time.

Low noise and high comfort

Noise index: $\leq 42\text{dB(A)}$

Low energy consumption

Power consumption lowest to 5W.

Multiple protection

With over-current protection

Quick release power plug

Start-up and stop the pump quickly.

Product photo and control modes



Performance curve

Constant speed mode performance curve

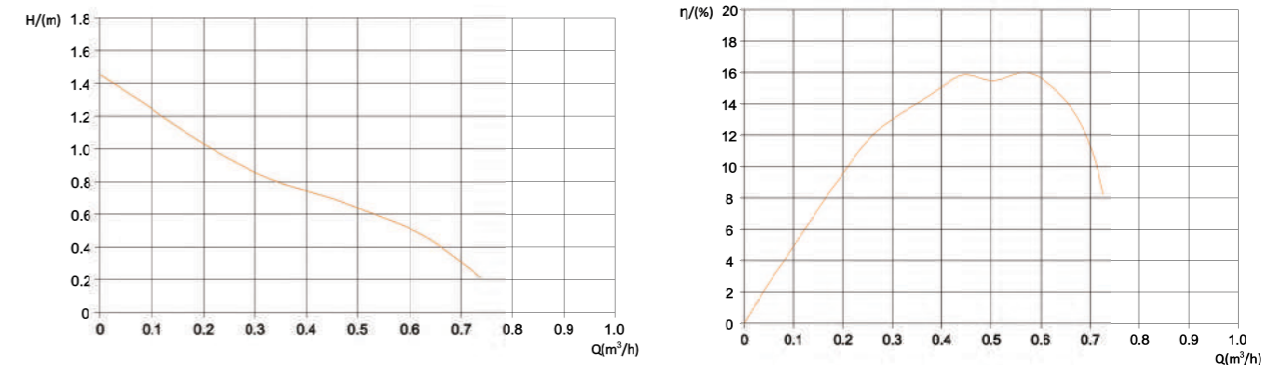

Technical parameter

Technical data

Power supply voltage	230V (+10% -15%) 50/60Hz, PE
Motor protection	No external protection required
IP class	IP44
Insulation class	H
Humidity (RH)	Max 95%
System pressure	1.0 MPa
Compliance	CE/ GS/ EMC/ LVD/RoHS/REACH
Ambient temperature	0°C~+40°C
Temperature class	TF110
Medium temperature	+2°C~+110°C(Glycol up to 50%)

Installation drawing

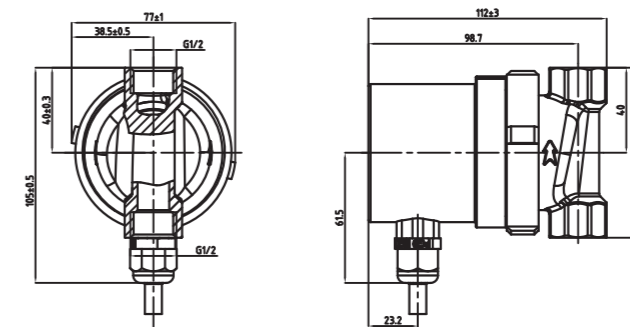

Performance parameter

Power (W)	Model	Max. Flow (m³/h)	Voltage/Frequency	Material	Control Mode of Motor Pump					Package size (mmxmmxmm)		Wt.(kg)	
					Constant speed running mode	Auto operation mode	Temperature Control mode	Timing mode	Flushing Function	Inner box	G.W.	N.W.	
5	Instant	0.9	230V 50/60Hz	Copper	●	/	/	/	/	180x115x150	1.2	1.0	

Grand HQ

High Efficiency Circulation Pump



Applications

1. Heating pump dual supply system
2. Underfloor heating mixed water system
3. Heating pump hot water system
4. HVAC
5. Boiler system
6. Other heating and cooling occasions. Suitable for refrigerants such as R290

Features and benefits

Cold and warm dual, ultra-low no leakage, long life

System adaptive, intelligent adjustment

Optional PWM stepless speed regulation

Key shift, convenient operation, power and fault display, running state at a glance

Condensate water out of the sink, heat insulation board design, for the system fluid transport escort

Multiple protection, A3 explosion-proof, high reliability

Product photo and control modes



Lighting area	Mode description	Illustration
AUTO	Automatic	<input type="radio"/> I <input type="radio"/> II <input type="radio"/> III <input checked="" type="radio"/> Auto
I	Constant speed low speed mode	<input checked="" type="radio"/> I <input type="radio"/> II <input type="radio"/> III <input type="radio"/> Auto
II	Constant speed medium speed mode	<input type="radio"/> I <input checked="" type="radio"/> II <input type="radio"/> III <input type="radio"/> Auto
III	Constant speed high speed mode	<input type="radio"/> I <input type="radio"/> II <input checked="" type="radio"/> III <input type="radio"/> Auto

Technical parameter

Technical data

Rated voltage	230V (+10% -15%) 50/60Hz, PE
Motor Protection	No external Protection requirements
Protection level	IP44
Insulation level	H
Humidity	≤95%
Design pressure	1.0MPa
Product Certification	CCC
Ambient temperature:	-30°C~55°C
Temperature class	TF95
Medium temperature:	-20°C~95°C(Glycol up to 50%)

Performance curve

Grand HQ 25-12 Performance curve

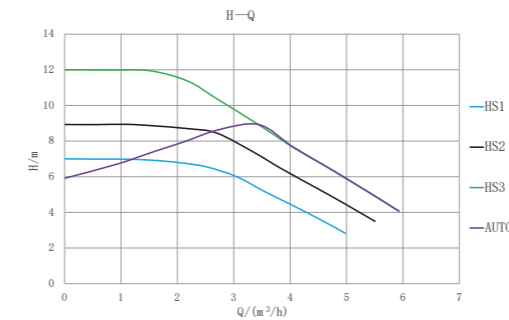

Grand HQ 32-12 Performance curve

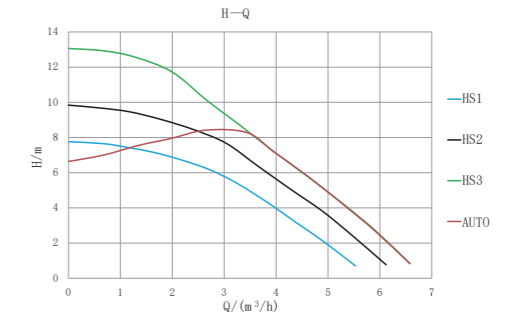

Grand HQ 25-15 Performance curve

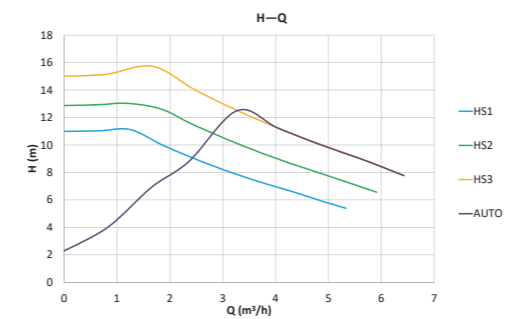

Grand HQ 32-15 Performance curve

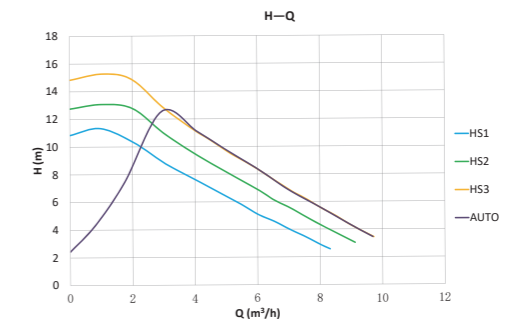

Grand HQ 25-18 Performance curve

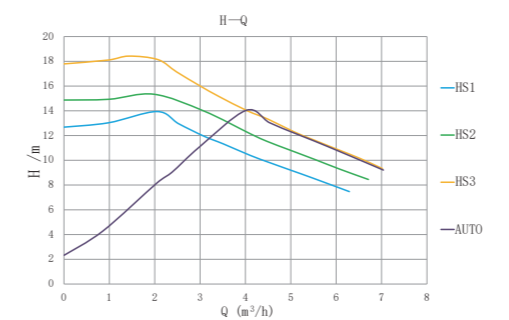

Grand HQ 32-18 Performance curve

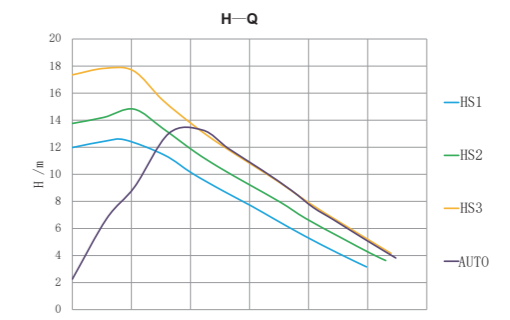

Installation drawing and performance parameter

Installation drawing

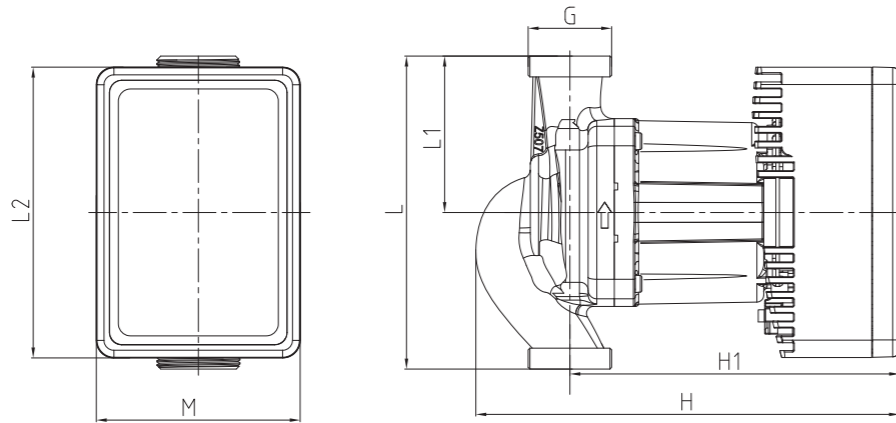

Model	Dimensions(mm)							Package size (mm*mm*mm)	Wt.(kg)	
	L	M	H	H1	L1	L2	G	Inner box	G.W.	N.W.
Grand HQ 25-12 130	130	90	168	126	65	130	1 1/2"	155x150x230	3.8	2.8
Grand HQ 25-12 180	180	90	169	133	90	130	1 1/2"	200x162x200	4	3
Grand HQ 25-15 180	180	117	244	190	90	180	1 1/2"	210x180x290	5.5	5.3
Grand HQ 25-18 180	180	117	244	190	90	180	1 1/2"	210x180x290	5.5	5.3
Grand HQ 32-12 180	180	90	169	133	90	130	2"	200x162x200	4.1	3.1
Grand HQ 32-15 180	180	117	244	190	90	180	2"	210x180x290	5.6	5.4
Grand HQ 32-18 180	180	117	244	190	90	180	2"	210x180x290	5.6	5.4

Performance parameter

Model	Max. Flow (m³/h)	Max. Head (m)	Power(W)		Current(A)		Voltage/Frequency (V/Hz)
			Min.	Max.	Min.	Max.	
Grand HQ 25-12	6.5	12	8	150	0.1	1.09	230V 50/60Hz
Grand HQ 25-15	8.5	15	19	270	0.14	1.6	
Grand HQ 25-18	9.5	18	60	350	0.44	2.5	
Grand HQ 32-12	6.5	12	8	150	0.1	1.09	
Grand HQ 32-15	10	15	19	270	0.16	1.7	
Grand HQ 32-18	11	18	60	350	0.44	2.5	